

# **Instruction manual**

## **Temperature probe and transducers for Pt1000 with (4-20) mA output**

*Air temperature probes  
P0120, P0122, P0132*

*Temperature transducers Pt1000  
P41x1*

## **Instruction manual of temperature probe P0120 and transducers P41x1**

Probe P0120 is designed for measurement of air temperature, transducers P0122 and P0132 for temperature measurement in stainless steel well (well is not included). Transducers P4121 to P4171 (next only P41x1) without own temperature sensors are designed for signal conversion from RTD sensor Pt1000 (3850ppm/°C) to current. All aforesaid devices have linear current output (4-20) mA for two wire connection.

### **Technical parameters:**

Type	Range	Current output	Accuracy	Formula for calculation of temperature	Formula for calculation of current
	[°C]	[mA]	[°C]	[°C, mA]	[mA, °C]
P0120, P0122	-30 to +80	4 to 20	±0,4	$T = 6.875 * I - 57.5$	$I = (T - 57.5) / 6.875$
P0132	0 to +150	4 to 20	±0,4°C <sup>(1)</sup> ±0,4% <sup>(2)</sup>	$T = 9.375 * I - 37.5$	$I = (T - 37.5) / 9.375$
P4141	-100 to +30	4 to 20	±0,3	$T = 8.125 * I - 132.5$	$I = (T - 132.5) / 8.125$
P4121	-30 to +80	4 to 20	±0,3	$T = 6.875 * I - 57.5$	$I = (T - 57.5) / 6.875$
P4151	0 to +35	4 to 20	±0,2	$T = 2.1875 * I - 8.75$	$I = (T - 8.75) / 2.1875$
P4131	0 to +150	4 to 20	±0,3	$T = 9.375 * I - 37.5$	$I = (T - 37.5) / 9.375$
P4161	0 to +250	4 to 20	±0,4	$T = 15.625 * I - 62.5$	$I = (T - 62.5) / 15.625$
P4171	0 to +400	4 to 20	±0,7	$T = 25 * I - 100$	$I = (T - 100) / 25$

Note:

(1) .... for temperature up to 100 °C

(2) ..... from reading, for temperatures over 100 °C

The accuracy of P0120 is determined for temperature at the end of the stem with airflow less than 0,5m/s.

The accuracy of transducer P41x1 is an input accuracy in respect of table value of sensor Pt1000/3850ppm.

#### **Current output in the case of error:**

P41x1: more than 24 mA in the case of disconnected probe

P41x1: less than 3.5 mA in the case of shorted probe

#### **Power:**

Power of device is allowed from 9V to 30V DC (typically 24V), maximum ripple 0.5 %

#### **Response time:**

P0120:  $t_{63} < 2$  min,  $t_{90} < 4$  min (temperature step from +25°C to +80°C, airflow c.1 m/s)

P01x2:  $t_{63} < 45$  s at temperature step (0..100) °C, stem with well immersed to fluid, flow velocity 1 m/s

P41x1: depends on connected temperature probe.

#### **Operating temperature and humidity range:**

Temperature of case -30 to 80 °C with humidity from 0 to 100 %RH without condensation

#### **Operational position:**

P0120: installation on the wall with the stem towards down

For transducers P41x1 and transmitters P01x2 in well there is no limitation in working position

#### **Outer characteristics in accordance with Czech National Standard 33-2000-3:**

Normal environment with the specifications: AM1, BE1, CB1

#### **Protection of electronic:**

IP65 (tighten glands, tighten case lid with inserted packing of lid)

#### **Storing conditions:**

Temperature from -30 to +80 °C, humidity from 0 to 100 %RH without condensation

*Not allowed manipulations:*

It is not allowed to operate the device under other than specified conditions in technical parameters. Devices are not designed for locations where mechanical vibrations can appear and for locations with chemically aggressive environment.

*Recalibration:* Interval of metrological verification depends on concrete application. Recommended period is about 1 year.

*Material of the case:* ABS

*Dimensions:* see dimension drawing, P0122 and P0132 differ from P0120 by stem construction

*Weight:* Approximately P0120 120 g, P0122 and P0132 140 g, P41x1 125 g

*Liquidation:* Device itself (after its life) is necessary to liquidate ecologically!

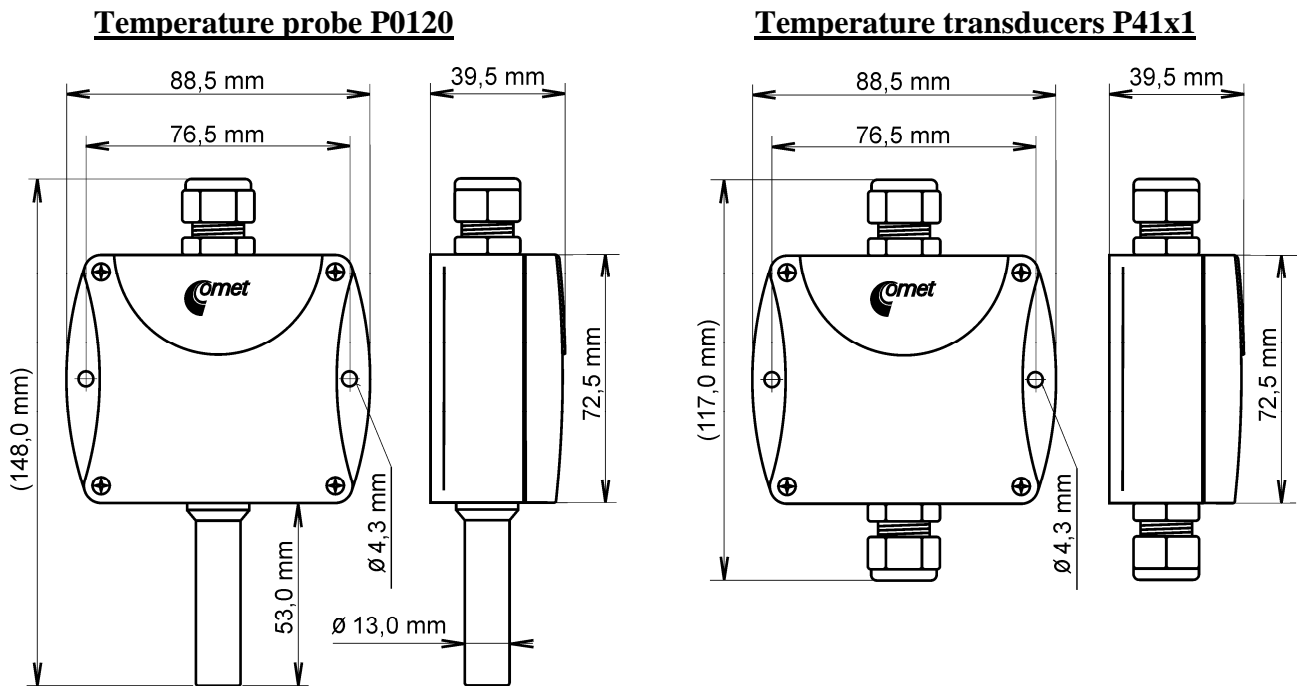

**Installation:**

Described devices are supplied from external power source by a cable. The cable is used for transmission of measurement temperature to sensing device too. It is recommended to use shielding copper cable (e.g. SYKFY) and the shielding connect to ground terminal of sensing side. Outside diameter of the cable must be from 4 to 8 mm, maximal cross-section area 2.5 mm<sup>2</sup> and maximal length 1200m. The cable must be located at indoor rooms (probe is not protected for outdoor use). The cable should not be led in parallel along power cabling. Safety distance is up to 0.5 m otherwise undesirable induction of interference signals can appear.

For connection of the cable is necessary to unscrew four screws at case corners and remove lid. Lace the cable through a gland at the case wall. Connect the cable to terminals with respecting the signal polarity (see figure). Terminals are self-clamping and can be opened by a suitable screwdriver. For the opening, insert the screwdriver to upper terminal hole and lever by him.

Transducers P41x1 in itself not measure a temperature. The temperature is measured an external two-wired probe Pt1000/3850ppm with shielding. Connection of the probe is similar to connection of power cable. Lace the probe cable through a second gland at the opposite site of the case. Connect the probe cable to three terminals (see figure). **Attention**, a shielding of probe cable must not be connected to anything else! Therefore it is suitable to secure probe cable towards mechanical damage. Restriction of the cable location is the same as the restriction of power cable location. That means the probe cable should not be located near to power of electronic jamming. Maximal length of probe cable is 10m.

Do not remember to tighten glands and case lid with inserted packing after cables connecting. It is necessary for warranting of protection IP65.

**Typical application circuitry:**

Range of power voltage  $U_0$  at input terminals of device can be from 9V to 30V. Whence it follows that absorbed power for current 20mA can be from 0.18W to 0.6W. The power made heating of the device. It is recommended to have it as small as possible. Small power voltage  $U_0$  can be ensured by optimum selection of voltage  $U_{SS}$  and resistor  $R_Z$ . If the voltage and resistor are fixed, it is possible to insert proper serial resistor  $R$  to the current loop at the sensing device side. Selection of the resistor  $R_Z$  or  $R$  can be made by graph. Device is able to work in zone no.2 and 3. The zone no.2 is optimal. Device is not able to operate in zone no.3. There are not ensured minimal power voltage of device  $U_0 = 9V$  for current 20mA.

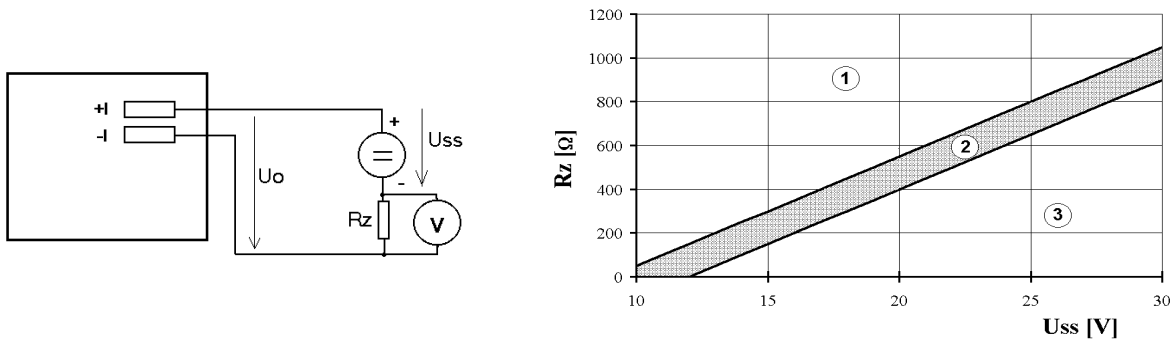

**Wiring of the terminals:**

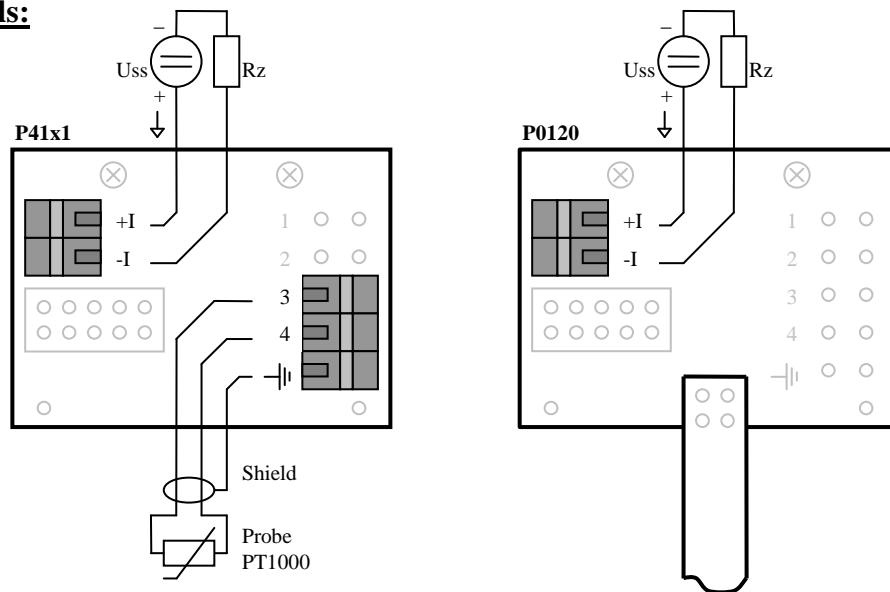

**Electromagnetic compatibility (EMC tests):**

Devices are conformed EN 61326-1 in the range:

- Radiation: EN 55022 class B
- Immunity: EN 61000-4-2 levels 4/8 kV, class A
- EN 61000-4-3 intensity of electromagnetic field 3 V/m, class A
- EN 61000-4-4 levels 1/0.5 kV, class A
- EN 61000-4-6 intensity of electromagnetic field 3 V/m, class A

**Technical support and service:**

Distributor of the devices provides a technical support and service. Contact to distributor is given at a warranty certificate.